

DATENBLATT

Sicherheitsventil / safety valve Typ : G14/G14-L



Zulassung/ homologation : CE 2014/68/EU
TÜV/ISPEL/ASME

Druckbereich / pressure range: 0,3-60,0 bar CE
1 – 60 bar ASME

**Anschlussgewinde / inlet connection :
oder / or** G 1/2" / G 3/4" / G1" (ISO 228)
R 1/2" / R 3/4" / R1" (ISO 7)
NPT 1/2" / 3/4" / 1"
1" / 1 1/2" TRI CLAMP
DN25/DN32 DIN 405-DIN 11851
DN15/DN20/DN25 PN 16/40 UNI
1/2" / 3/4" / 1" ANSI 150/300

Ausgangsgewinde / outlet connection: G1 (ISO 228)
DN25 PN 16/40UNI
1" ANSI 150/300
1" NPT
1 1/2" TRI CLAMP
DN25/32 DIN 405-DIN 11851

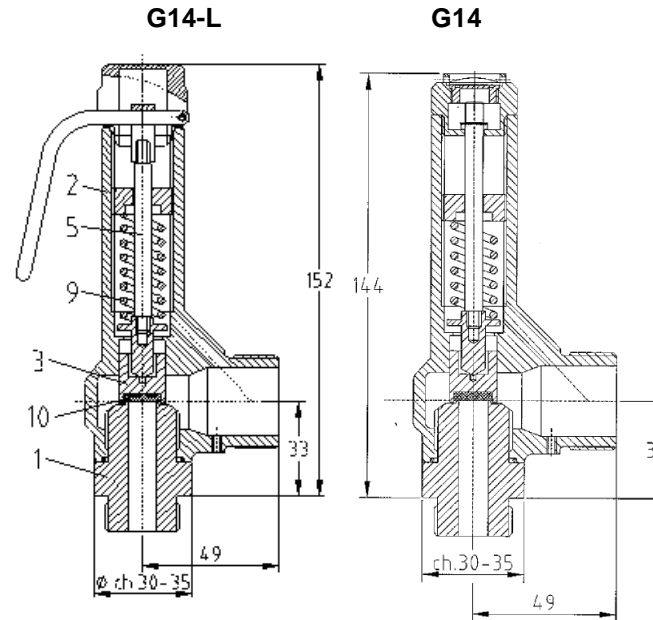

Leistungsdaten Durchfluss/ flow range	
Luft / air	
Druck / Set pressure (bar)	kg/h
1	214
2	338
3	465
4	584
5	703
6	822
7	941
8	1060
9	1179
10	1298
11	1417
12	1536
13	1655
14	1774
15	1893
16	2012
17	2131
18	2250
19	2369
20	2488
21	2607
22	2726
23	2845
24	2964
25	3083
26	3202
28	3440
30	3678
32	3916
34	4154
36	4392
38	4630
40	4867
42	5105
44	5343
46	5581
48	5819
50	6057
55	6652
60	7247

Bauteilwerkstoffe	1	2	3
	-196/ +250°C	-196/ +250°C	-196/ +450°C
Ventilvariante /Materialausführung	Messing / brass	Messing/Edelstahl-Eingang brass/inlet stainless steel	Edelstahl/stainless steel
Einlaufstück /inlet	Messing/brass	Edelstahl / stainless steel	Edelstahl/ stainless steel
Gehäuse / body	Messing/brass	Messing/brass	Edelstahl / stainless steel
Kegel / cone	Messing/brass	Messing/brass	Edelstahl / stainless steel
Zugstange / spindle	Messing/brass	Messing/brass	Edelstahl / stainless steel
Einstellschraube / adjusting screw	Messing/brass	Messing/brass	Edelstahl / stainless steel
Druckfeder / spring	Stahl verz. EN 10270-1DH	Edelstahl / stainless steel	Edelstahl / stainless steel

k: 0,81 (>=3bar 0,86) CE
0,629 ASME

Nennweite / nominal size: 13,5 mm

*Die angegebenen Leistungen werden bei 10% (PE <1 bar, + 0, 1bar) **Druckanstieg** erreicht, gemessen mit Druckluft bei 0°C. Für andere Gase und Temperaturen ändern sich die Abblaseleistungen.
*The specified rates are measured at 10% (PE <1 bar, + 0,1 bar) pressure rise over the set pressure with compressed air at 0°C. The blowoff rates are different for other gases and temperatures

DATENBLATT

Sicherheitsventil / safety valve Typ : G14/G14-L



Mögliche Ausführungen – Medienverträglichkeiten

Dichtung	NBR			EPDM			VITON (FPM)			TEFLON (PTFE)			VQM			METALL Edelstahl			KALREZ		
----------	-----	--	--	------	--	--	-------------	--	--	---------------	--	--	-----	--	--	------------------	--	--	--------	--	--

Materialausführung	1	2	3	1	2	3	1	2	3	1	2	3	1	2	3	2	3	1	2	3
--------------------	---	---	---	---	---	---	---	---	---	---	---	---	---	---	---	---	---	---	---	---

Anwendungstemperatur	[°C]																			
----------------------	------	--	--	--	--	--	--	--	--	--	--	--	--	--	--	--	--	--	--	--

min	-10	-10	-10	-50	-50	-50	-20	-20	-20	-196	-60	-196	-196	-20		
max	+100	+100	+100	+150	+150	+150	+200	+200	+200	+250	+200	+250	+450	+250	+250	+275

Medien G=gasförmig (bei RT und 1bar) F=flüssig ○ = neutral/unbedenklich ■ = brennbar + = giftig ■ = brennbar und giftig

Argon	x	x	x	x	x	x	x	x	x	x	x	x	x	x	x	x	x	x	○	G
Helium He	x	x	x	x	x	x	x	x	x	x	x	x	x	x	x	x	x	x	○	G
Kohlendioxid CO2	x	x	x	x	x	x	x	x	x	x	x	x	x	x	x	x	x	x	○	G
Luft	x	x	x	x	x	x	x	x	x	x	x	x	x	x	x	x	x	x	○	G
Neon	x	x	x	x	x	x	x	x	x	x	x	x	x	x	x	x	x	x	○	G
Sauerstoff O2				x	x	x	x	x	x	x	x	x	x	x	x	x	x	x	○	G
Stickstoff N2	x	x	x	x	x	x	x	x	x	x	x	x	x	x	x	x	x	x	○	G

Weitere Medien auf Anfrage
Other mediums on request

Technische Änderungen, Druckfehler oder Irrtümer vorbehalten, Abbildungen sind nicht verbindlich.

We reserve the right to make technical modifications. Errors or printing errors excepted. Illustrations are not binding.