

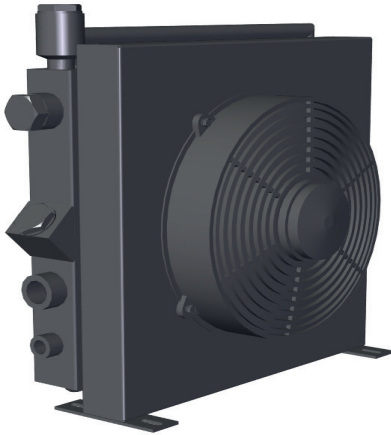

HCD air cooler

HENNLICH - Cooling - Technologies GmbH

HCD-aircooler with DC-motor



This cooler type with direct current motor(12V / 24V) is for stationary and mobile applications and has been developed for efficient cooling of hydraulic and lubrication oil and for water/glycol mixtures (at least 15 % glycol).
 Designs available incl. various accessories (fan soft control or/and terminal box) and as 1-pass, 2-pass or 3-pass.

Material	
Cooling element	Aluminium (copper or stainless steel upon request)
Air fan	glass fibre reinforced plastic (PPG)
Sheet metall parts	C-steel powder coated
Protection grid	glass fibre reinforced plastic (PPG)
Main parts	black color RAL 9005

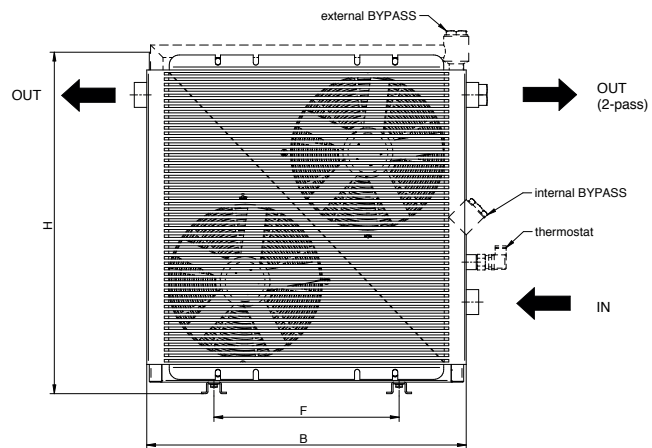
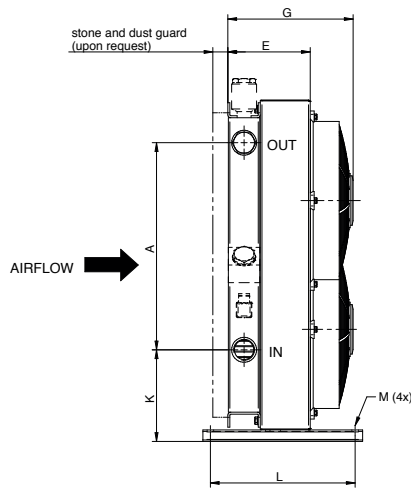

HENNLICH Cooling-Technologies		noise level LpA dB (A) 1m*	power input [A]	mass [kg]	B	F	H	J	L	A	E	G	Mø
HCD standard sizes													
HCD	B21.21-12	66	8	4	210	220	255	G3/4	80	136	100	155	9x14
HCD	B21.21-24	66	4	4	210	220	255	G3/4	80	136	100	155	9x14
HCD	C27.21-12	68	8	6	270	220	255	G1	80	-	122	175	9x14
HCD	C27.21-24	68	4	6	270	220	255	G1	80	-	122	175	9x14
HCD	C33.26-12	72	18	9	335	300	344	G1	90	159	107	200	9x20
HCD	C33.26-24	72	10	9	335	300	344	G1	90	159	107	200	9x20
HCD	C40.33-12	73	18	12	405	360	398	G1	100	234	127	220	9x25
HCD	C40.33-24	73	10	12	405	360	398	G1	100	234	127	220	9x25
HCD	C47.40-12	73	18	16	470	416	468	G1	100	225	127	220	9x25
HCD	C47.40-24	73	10	16	470	416	468	G1	100	225	127	220	9x25
HCD	C55.48-12	75	20	21	550	356	638	G1	290	308	127	220	12x15
HCD	C55.48-24	75	10	21	550	356	638	G1	290	308	127	220	12x15
HCD	C64.59-12	78	2x18	30	640	356	680	G1¼	290	406	167	260	12x15
HCD	C64.59-24	78	2x10	30	640	356	680	G1¼	290	406	167	260	12x15

Other cooler types / dimensions upon request
 Noise level tolerance +/- 3 dB(A)



HCD air cooler

HENNLICH - Cooling - Technologies GmbH

HCD-aircooler with DC-motor

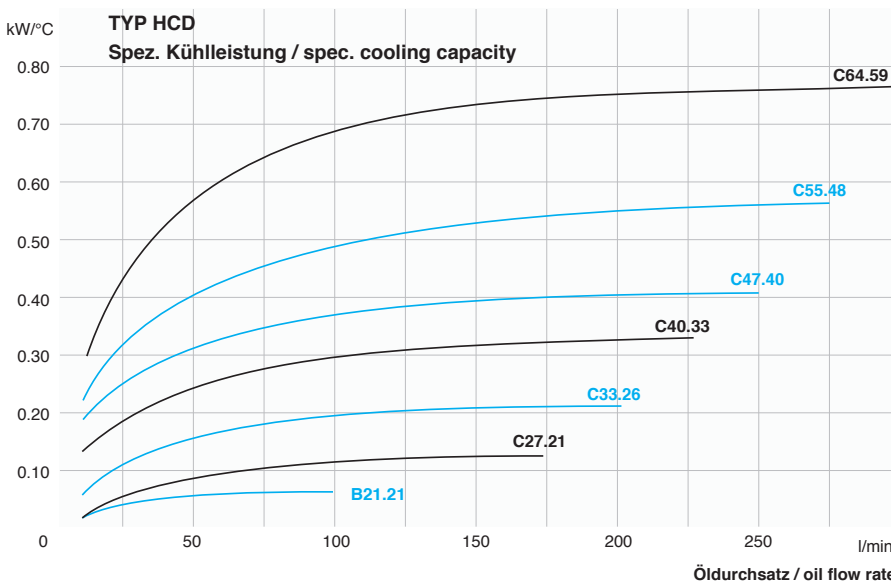
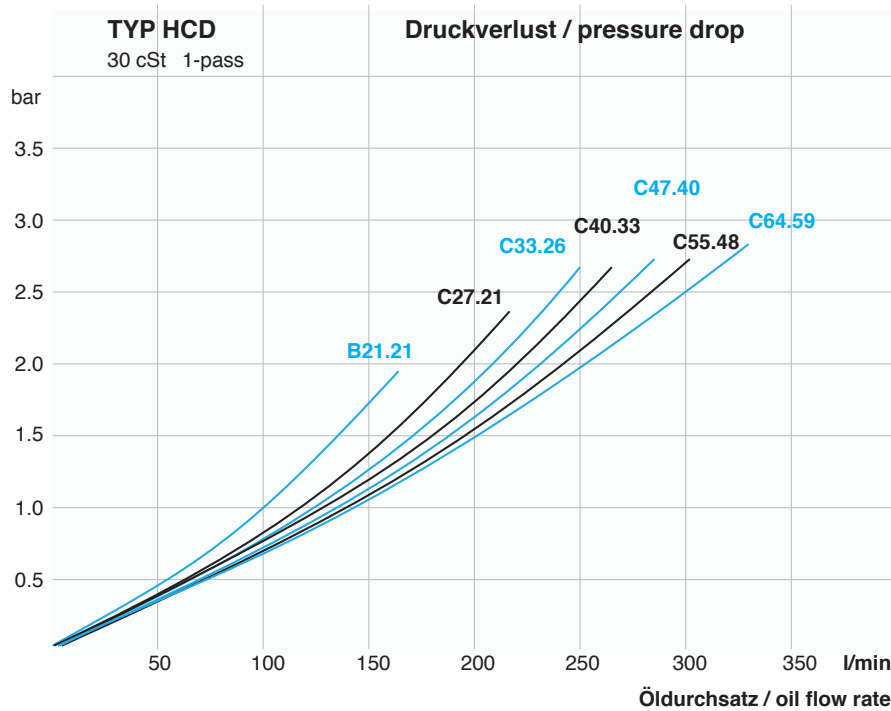

Selection of cooler:

The specific cooling capacity (y-axis) can be determined with the oil flow rate (x-axis) and the intersection of the cooler type curve.

In order to get the actual cooling capacity it has to be multiplied with the temperature-difference of the max. oil temperature (= cooler inlet) and the max. air temperature suctioned to the cooler.

Example:

Max. oil temperature: 70 °C

Max. air temperature: 30 °C

($\Delta t = 40$ °C temperature difference)

Oil flow rate: 100 l/min

For cooler type C55.48 with spec. cooling capacity of 0,48 kW/°C (acc. chart) multiplied by $\Delta t = 40$ °C results a cooling capacity of 19,2 kW

The characteristic curves are based on data of typical hydraulic oil at 60 °C and can differ due to other physical figures.

To calculate thermal dissipation loss or cooling power we provide support in any case!

Please note that dust, dirt or circulating air can cause a loss of capacity. Consider some safety or contact a HENNLICH Cooling technician!

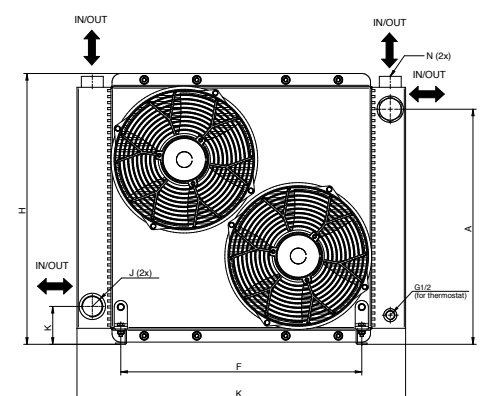

New: The Flex-Design => with in and outlets in all directions => for flexible connection

Other Types:

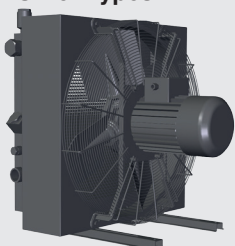

HCA with AC-Motor

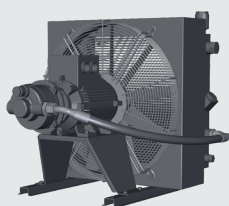

HCP with AC-Motor + pump



HCH with hydraulic-motor

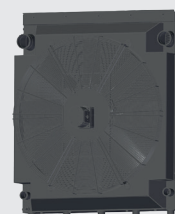

HCC for diesel engines

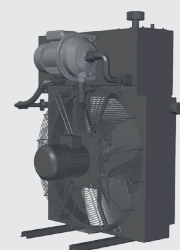

HCS cooling systems



HCD air cooler

HENNLICH - Cooling - Technologies GmbH

Key code

HCD - C33.26 – 24 - 100 - TSS - Z

Cooler type	
HCD	air cooler with DC-motor
HCDF	Flex-design with DC-motor
Cooler size	
B21.21 bis XXXX	acc. table
Motor voltage	
12	DC-motor 12 VDC
24	DC-motor 24 VDC
Bypass accessories	
1XX	1-pass excl. bypass valve
2XX	standard 2-pass
3XX	standard 3-pass
5XX	2-pass with accesories
X2X	bypass valve (2 bar)
X5X	bypass valve (5 bar)
XX4	thermostat 40 °C
XX5	thermostat 50 °C
XX6	thermostat 60 °C
XX7	thermostat 70 °C
XX8	thermostat 80 °C
XX9	thermostat 90 °C
X25	with internal thermal-bypass (2 bar, 50 °C)
X26	with internal thermal-bypass (2 bar, 60 °C)
Internal codes	
TSS	internal codes
Internal codes	
Z	Options for stone and dust guard, painting, filter, accessories, ...

Max. oil temperature [Tmax]	120 °C
Max. oil pressure	26 bar (statically, under standard conditions)
General motor data:	IP67 (IP68)

Motor type plate has to be noted as well.

Higher pressure rates upon request.

If water/glycol is used, the cooling characteristics are better. Please send us the mixture and the technical data or fill in and send us the technical questionnaire on our website: www.hennlich.at